

# Toaster

USE AND CARE GUIDE  
MODELS T475R AND T475C



# IMPORTANT SAFEGUARDS

When using electrical appliances, basic safety precautions should always be followed including the following:

- ◆ Read all instructions.
- ◆ Do not touch hot surfaces. Use handles or knobs.
- ◆ To protect against electrical shock do not immerse cord, plugs, or appliance in water or other liquid.
- ◆ Close supervision is necessary when any appliance is used by or near children.
- ◆ Unplug from outlet when not in use and before cleaning. Allow to cool before putting on or taking off parts.
- ◆ Do not operate any appliance with a damaged cord or plug or after the appliance malfunctions or has been damaged in any manner. Contact Consumer Service for examination, repair or adjustment.
- ◆ The use of accessory attachments not recommended by the appliance manufacturer may cause injuries.
- ◆ Do not use outdoors.
- ◆ Do not let cord hang over edge of table or counter, or touch hot surfaces.
- ◆ Do not place on or near a hot gas or electric burner, or in a heated oven.
- ◆ To disconnect, press Cancel Button and remove plug from wall outlet.
- ◆ Do not use appliance for other than intended use.
- ◆ Oversize foods, metal foil packages, or utensils must not be inserted in a toaster as they may involve a risk of fire or electric shock.
- ◆ A fire may occur if toasters are covered or touching flammable material, including curtains, draperies, walls, and the like, when in operation.
- ◆ Do not attempt to dislodge food when toaster is plugged in.

## SAVE THESE INSTRUCTIONS For Household Use Only



# ADDITIONAL IMPORTANT SAFEGUARDS

**CAUTION HOT SURFACES:** This appliance generates heat and escaping steam during use. Proper precautions must be taken to prevent the risk of burns, fires, or other injury to persons or damage to property.

- ◆ A person who has not read and understood all operating and safety instructions is not qualified to operate this appliance. All users of this appliance must read and understand this Use and Care Guide before operating or cleaning this appliance.
- ◆ If this appliance falls or accidentally becomes immersed in water, unplug it from the wall outlet immediately. **Do not reach into the water!**
- ◆ When using this appliance, provide adequate air space above and on all sides for air circulation. Do not operate this appliance while it is touching or near curtains, wall coverings, clothing, dishtowels or other flammable materials.
- ◆ To reduce the risk of fire, do not leave this appliance unattended during use.
- ◆ If this appliance begins to malfunction during use, immediately unplug the cord. Do not use or attempt to repair a malfunctioning appliance!
- ◆ The cord to this appliance should only be plugged into a 120V AC electrical wall outlet.
- ◆ Do not use this appliance in an unstable position.
- ◆ Use the Toaster on a hard, flat surface. Do not place it near a flame or heat or on a soft surface (such as carpet). Avoid placing it where it may tip over during use. Dropping the Toaster could cause it to malfunction.
- ◆ If this appliance begins to malfunction during use, immediately push the Cancel Button and unplug the cord. Do not use or attempt to repair the malfunctioning appliance.
- ◆ **WARNING: ELECTRICAL SHOCK HAZARD.** Never attempt to dislodge food inside the Toaster while the Toaster is plugged in. Doing so could cause an electrical shock hazard or a risk of fire.

- ◆ **CAUTION:** This appliance is hot during operation and retains heat for some time after turning off. Always use oven mitts when handling hot materials and allow metal parts to cool before cleaning. Do not place anything on top of the Toaster while it is operating or while it is hot.
- ◆ **CAUTION:**
  - DO NOT** toast pastries with runny fillings or frosting.
  - DO NOT** toast torn slices of bread.
  - DO NOT** place buttered bread or wrapped food into the Toaster.
  - DO NOT** toast small-size breads, mini-baguettes, breadsticks, etc.

## Polarized Plug

This appliance has a polarized plug (one blade is wider than the other). To reduce the risk of electrical shock, this plug is intended to fit into a polarized outlet only one way. If the plug does not fit fully in the outlet, reverse the plug. If it still does not fit, contact a qualified electrician. Do not attempt to modify the plug in any way.

## Short Cord Instructions

A short power-supply cord is provided to reduce the risk resulting from becoming entangled in or tripping over a longer cord.

Do not use an extension cord with this product.

## Electric Power

If the electrical circuit is overloaded with other appliances, your appliance may not operate properly. It should be operated on a separate electrical circuit from other appliances.

## Plasticizers Warning

**CAUTION:** To prevent Plasticizers from migrating from the finish of the countertop or tabletop or other furniture, place **NON-PLASTIC** coasters or placemats between the appliance and the finish of the countertop or tabletop.

**Failure to do so may cause the finish to darken, permanent blemishes may occur or stains can appear.**



# Getting To Know Your Toaster

Your product may vary slightly from illustration.

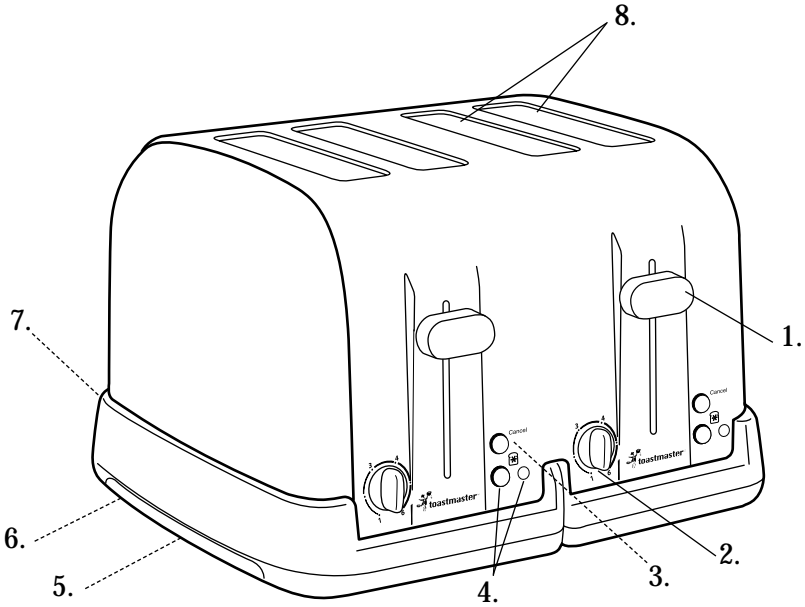

- 1. Toast Lever
- 2. Toast Color Control
- 3. Cancel Button
- 4. Defrost Button and Light
- 5. Cord Storage
- 6. Cord Slot
- 7. Slide-Out Crumb Trays (P/N 21624)
- 8. Self-Adjusting Bread Slots with Pastry Shutters

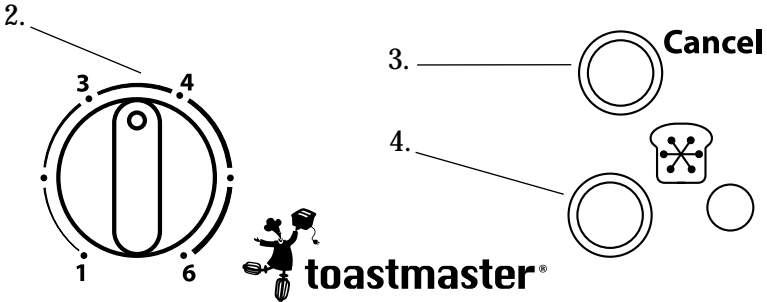

# Toasting Instructions

1. Plug cord into any 120 V ~ 60 Hz outlet. The unit may emit an odor and/or smoke during first few uses from oils used in manufacturing. This is normal for a new appliance.
2. Set Toast Color Control to the color of toast desired. For first use, set control mid-way between Light (1) and Dark (6) settings. Toast thin breads on the lower toast color setting.
3. Insert bread or toaster food into Bread Slots and push down Toast Lever. The toaster has even-heat Pastry Shutters that automatically close to provide more uniform toasting and faster baking of frozen toaster pastries.

**NOTE:** Use any slot when toasting single slice or portion. Use portions that fit freely into slots. The Self-Adjusting Bread Slots will hold food upright for uniform toasting.

4. When toast is done, the Toast Lever will pop up and the power will shut off automatically. Lift up on Toast Lever for easier removal of shorter foods like bagels and English muffins.
5. To interrupt toasting, press the Cancel Button.
6. Unplug cord from wall outlet when not in use.

**NOTE:** To prevent a fire hazard, never place bread over the opening of the Toaster, but always place it into the Bread Slot.

# Defrost/Toasting Instructions

1. Plug cord into any 120 V ~ 60 Hz outlet. The unit may emit an odor and/or smoke during first few uses from oils used in manufacturing. This is normal for a new appliance.
2. For first use, set Toast Color Control to the Light (1) setting.



## Defrost/Toasting Instructions (cont.)

3. Place frozen food in the toaster slots. PUSH DOWN ON THE TOAST LEVER FIRST AND THEN PRESS THE DEFROST BUTTON. The Defrost Light will go on.

**NOTE:** The defrost/toasting process will automatically toast for approximately 20 seconds longer to assure that the item will be defrosted as well as toasted. Use any slot when toasting only one frozen food item. Use food that fits freely into slots. The Self-Adjusting Bread Slots hold food upright for uniform toasting.

4. When the food is done, the Toast Lever will pop up and the Defrost Button will release. The power will shut off automatically and the Defrost Light will go off. The automatic reset feature returns the toaster to normal operation after each defrost/toasting cycle.
5. To interrupt toasting, press the Cancel Button.
6. Unplug cord from wall outlet when not in use.

## Convenience Foods Toasting

Today there are many varieties of packaged convenience foods available, both frozen and non-frozen (shelf pastry), that can be toasted in your toaster.

Since toaster foods and individual tastes vary, it is difficult to recommend exact Toast Color settings, however, after a little experimentation you will discover the best setting for your needs. You may also wish to refer to the heating instructions on food packaging. For thicker convenience foods, it may be necessary to adjust Toast Color Control clockwise for a longer toasting cycle.

# Removing Lodged Toast

If a piece of toast becomes lodged in the Toaster, unplug the Toaster and allow to cool. Press the Toasting Lever down. Turn the Toaster upside down, and shake the toast loose.

**IMPORTANT:** Never use a fork or sharp-edged utensil to remove toast, because that may damage the heating element or cause injury.

## Important Points

1. Remove all protective wrapping from food before placing in Toasting Slots.
2. For best results, clean Crumb Tray frequently.
3. Different breads require different color settings. Turn the Toast Color Control knob counter-clockwise to the CANCEL position at any time to check toast color.
4. Do not block top openings. Do not place any object over the top openings.
5. Do not toast buttered bread or buttered pita bread. Melted butter will cause fire.
6. Bread, which has been toasted but not buttered, may be reheated. Use a lighter setting and watch it carefully.
7. When toasting more than one slice of bread, use slices of similar size, thickness and freshness.
8. Stale bread, thin or sweet bread products, such as teacakes and fruit loaf, brown much more quickly than ordinary bread, so they should be toasted on the lighter setting.
9. Never immerse Toaster in water.
10. Never use a fork or sharp utensils to remove toast, because that may damage the heating element or cause injury.





# User Maintenance Instructions

This appliance requires little maintenance. It contains no user serviceable parts. Do not try to repair it yourself. Any servicing requiring disassembly other than cleaning must be performed by a qualified appliance repair technician.

## Cleaning Instructions

**CAUTION: Do not immerse in water or other liquid.**

1. Unplug toaster and allow to cool.
2. Wipe outside with soft, damp cloth. Polish with soft, dry cloth.
3. Remove Slide-Out Crumb Trays using recessed handles in rear of toaster. Shake out crumbs in toaster over sink. Wash Crumb Trays in top rack of dishwasher or by hand with warm, sudsy water, then rinse and dry.
4. Be sure to slide Crumb Trays back into position before attempting to toast again. Do not let food build up in the crumb trays.

## To Store

Unplug unit, allow to cool, and clean before storing. Store in its box in a clean, dry place. Never store it while it is hot or still plugged in. Never wrap cord tightly around the appliance. The cord may be wound using the Cord Storage area on bottom of unit. Do not put any stress on the cord where it enters the unit, as it could cause the cord to fray and break.

## LIMITED ONE YEAR WARRANTY

**Warranty:** This Toastmaster® product is warranted to be free from defects in materials or workmanship for a period of (1) year from the original purchase date. This product warranty covers only the original consumer purchaser of the product.

**Warranty Coverage:** This warranty is void if the product has been damaged by accident in shipment, unreasonable use, misuse, neglect, improper service, commercial use, repairs by unauthorized personnel, normal wear and tear, improper assembly, installation or maintenance abuse or other causes not arising out of defects in materials or workmanship. This warranty is effective only if the product is purchased and operated in the USA, and does not extend to any units which have been used in violation of written instructions furnished with the product or to units which have been altered or modified or to damage to products or parts thereof which have had the serial number removed, altered, defaced or rendered illegible.

**Implied Warranties:** ANY IMPLIED WARRANTIES WHICH THE PURCHASER MAY HAVE ARE LIMITED IN DURATION TO ONE (1) YEAR FROM THE DATE OF PURCHASE. Some states do not allow limitations on how long an implied warranty lasts, so the above limitation may not apply to you.

**Warranty Performance:** During the above one-year warranty period, a product with a defect will be either repaired or replaced with a reconditioned comparable model (at our option) when the product is returned to the Repair Center, or the purchase price refunded. The repaired or replacement product will be in warranty for the balance of the one-year warranty period and an additional one-month period. No charge will be made for such repair or replacement.

**Service and Repair:** Should the appliance malfunction, you should first call toll-free 1 (800) 947-3744 between the hours of 9:00 am and 5:00 pm Central Standard Time and ask for CONSUMER SERVICE stating that you are a consumer with a problem. Please refer to model number T475R and T475C when you call.

**In-Warranty Service (USA):** For an appliance covered under the warranty period, no charge is made for service or postage. Call for return authorization 1 (800) 947-3744.

**Out-of Warranty Service:** A flat rate charge by model is made for out-of-warranty service. Include \$ 8.00 (U.S.) for return shipping and handling. We will notify you by mail of the amount of the charge for service and require you to pay in advance for the repair or replacement.

**For Products Purchased in the USA, but Used in Canada:** You may return the product insured, packaged with sufficient protection, and postage and insurance prepaid to the USA address listed below. Please note that all customs duty / brokerage fees, if any, must be paid by you and we will require you to pay the cost of customs duty / brokerage fees to us in advance of our performing any service.

**Risk During Shipment:** We cannot assume responsibility for loss or damage during incoming shipment. For your protection, carefully package the product for shipment and insure it with the carrier. Be sure to enclose the following items with your appliance: any accessories related to your problem, your full return address and daytime phone number, a note describing the problem you experienced, a copy of your sales receipt or other proof of purchase to determine warranty status. C.O.D. shipments cannot be accepted.

### To return the appliance, ship to:

Attn: Repair Center  
Toastmaster Inc.  
708 South Missouri Street  
Macon, MO 63552  
Email: [consumer\\_relations@toastmaster.com](mailto:consumer_relations@toastmaster.com)  
[www.toastmaster.com](http://www.toastmaster.com)

### To contact us, please write to or call:

Toastmaster Inc.  
P.O. Box 6916  
Columbia, MO 65205-6916  
1 (800) 947-3744

**Limitation of Remedies:** No representative or person is authorized to assume for us any other liability in connection with the sale of our products. There shall be no claims for defects or failure of performance or product failure under any theory of tort, contract or commercial law including, but not limited to negligence, gross negligence, strict liability, breach of warranty and breach of contract. Repair, replacement or refund shall be the sole remedy of the purchaser under this warranty, and in no event shall we be liable for any incidental or consequential damages, losses or expenses. Some states do not allow the exclusion or limitation of incidental or consequential damages, so the above limitation or exclusion may not apply to you.

**Legal Rights:** This warranty gives you specific legal rights, and you may also have other rights which vary from state to state.

© 2003 Toastmaster Inc.  
All Rights Reserved

P/N 60935Rev.1  
Printed in China



toastmaster®

## Keep Dated Sales Receipts for Warranty Service.

Keep this booklet. Record the following for reference:

Date purchased \_\_\_\_\_

Model number \_\_\_\_\_

Date code (stamped on bottom) \_\_\_\_\_

EVERYBODY EATS. It's a fact of life.

But sometimes preparing  
meals can become a chore.

That's why TOASTMASTER has been invited  
into millions of kitchens just like yours  
so we can HELP YOU MASTER your  
mixing, baking, grilling, toasting,  
brewing, heating and serving  
tasks WITH EASE AND STYLE.

The TOASTMASTER name stands for a  
CELEBRATION of INNOVATION designed  
to serve your life and keep you  
COOKIN' IN STYLE.

# Contact Information

## Coordonnées :

## Contacte a:

### **Toastmaster Inc.**

National Service Center  
708 South Missouri Street  
Macon, Mo 63552

In USA and Canada call:

**Consumer Service: 1-800-947-3744**

**Consumer Parts: 1-800-947-3745**

**consumer\_relations@toastmaster.com**

**Hours: 8:00 A.M. - 5:30 P.M. CST**

Aux USA et au Canada, appeler les numéros suivants :

**Service Consommateurs : 1-800-947-3744**

**Pièces Consommateurs : 1-800-947-3745**

**consumer\_relations@toastmaster.com**

**Horaires : De 8h00 à 17h30, heure GMT - 6**

En México:

Toastmaster de México, S.A. de C.V.

Cerrada de Recursos

Hidráulicos Número 6

La Loma Industrial

Tlalnepantla de Baz, C.P. 54060

Estado de México

**52-5-397-2848**

**Horario: 8:00 a.m. hasta 5:30 p.m., hora del Centro**

## CONTACT US/APPELEZ



**1-800-947-3744**



**www.toastmaster.com**



**consumer\_relations@toastmaster.com**

©2003 Toastmaster Inc.

A Subsidiary of Salton, Inc.

Subsidiaria de Salton, Inc.

A una Subsidiaria de Salton, Inc.



**toastmaster®**

**11.**





- Extra-wide bagel-size slots
- Even heat pastry shutters
- Self-adjusting bread slots
- Cancel and defrost buttons
- Electronic toast color control
- Slide-out crumb tray



## **Questions**

Call toll free 1-800-947-3744

Monday – Friday, 8:00 a.m. - 5:30 p.m. CST

[www.toastmaster.com](http://www.toastmaster.com)

**T475R AND T475C**